

VOGUE

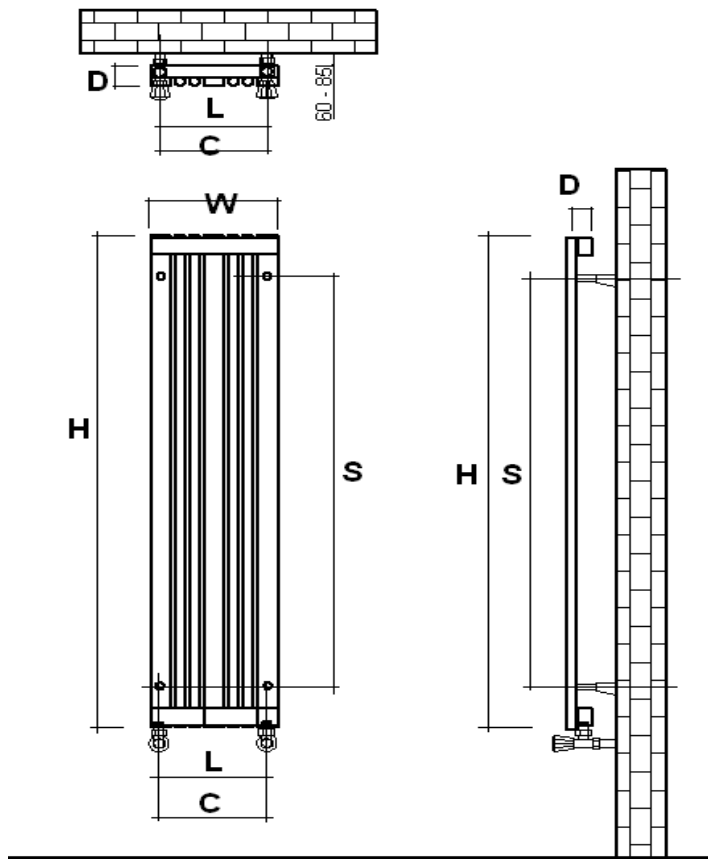

Материал	Поверхность	Тестовое давление	Мах.рабочее давление	Максимальная температура	Тепловая мощность	Соединение	Гарантия (лет)
Нержавеющая сталь 304	Матовая	13 BAR	10 BAR	95	EN 442	1/2"	10

Размер			Стена		Вода		Теплоотдача 90 - 70 - 20			Объем Воды ml	Нетто Вес Kg	Электрическая версия Watt
Высота mm	Ширина mm	Толщина a mm	Центр Соединения		Центр Соединения		Btu/hr	Watts	Kcal/hr			
H	W	D	S	L	C							

600	480	50	400	440	550	2.213	649	559	4.065	9,089	300
600	810	50	400	550	550	3.702	1.086	935	6.771	15,208	600
600	1470	50	400	1210	550	6.681	1.959	1.687	12.183	27,445	Not
600	1690	50	400	1390	550	7.673	2.251	1.938	13.987	31,524	Not
600	1910	50	400	1650	550	8.666	2.542	2.188	15.791	35,604	Not
800	370	50	500	330	330	2.194	644	554	3.971	9,009	Not
800	590	50	500	330	550	3.462	1.015	874	6.230	14,216	600
800	700	50	500	440	660	4.096	1.201	1.034	7.359	16,820	600
1000	370	50	700	330	330	2.672	784	675	4.779	10,969	Not
1000	480	50	700	440	440	3.443	1.010	870	6.136	14,137	600
1000	700	50	700	440	660	4.986	1.462	1.259	8.850	20,472	1000
1200	260	50	900	220	220	2.241	657	566	4.003	9,198	Not
1200	480	50	900	440	440	4.059	1.190	1.025	7.171	16,661	Not
1200	590	50	900	330	550	4.968	1.457	1.254	8.756	20,392	600
1500	260	50	1200	220	220	2.580	757	651	4.874	11,292	Not
1500	370	50	1200	330	330	3.625	1.063	915	6.799	15,869	Not
1500	480	50	1200	440	440	4.670	1.370	1.179	8.725	20,447	Not
1800	260	50	1500	220	220	3.058	897	772	5.745	13,386	Not
1800	370	50	1500	330	330	4.297	1.260	1.085	8.011	18,809	Not
1800	480	50	1500	440	440	5.536	1.624	1.398	10.278	24,233	Not
2000	260	50	1700	220	220	3.378	991	853	6.325	14,782	Not
2000	370	50	1700	330	330	4.745	1.392	1.198	8.819	20,769	Not

2000	480	50	1700	440	440	6.113	1.793	1.544	11.313	26,757	Not
------	-----	----	------	-----	-----	-------	-------	-------	--------	--------	-----